

PRODUCT SUBMITTAL

WIRE-BOND

Partition Top Anchor (#4301)

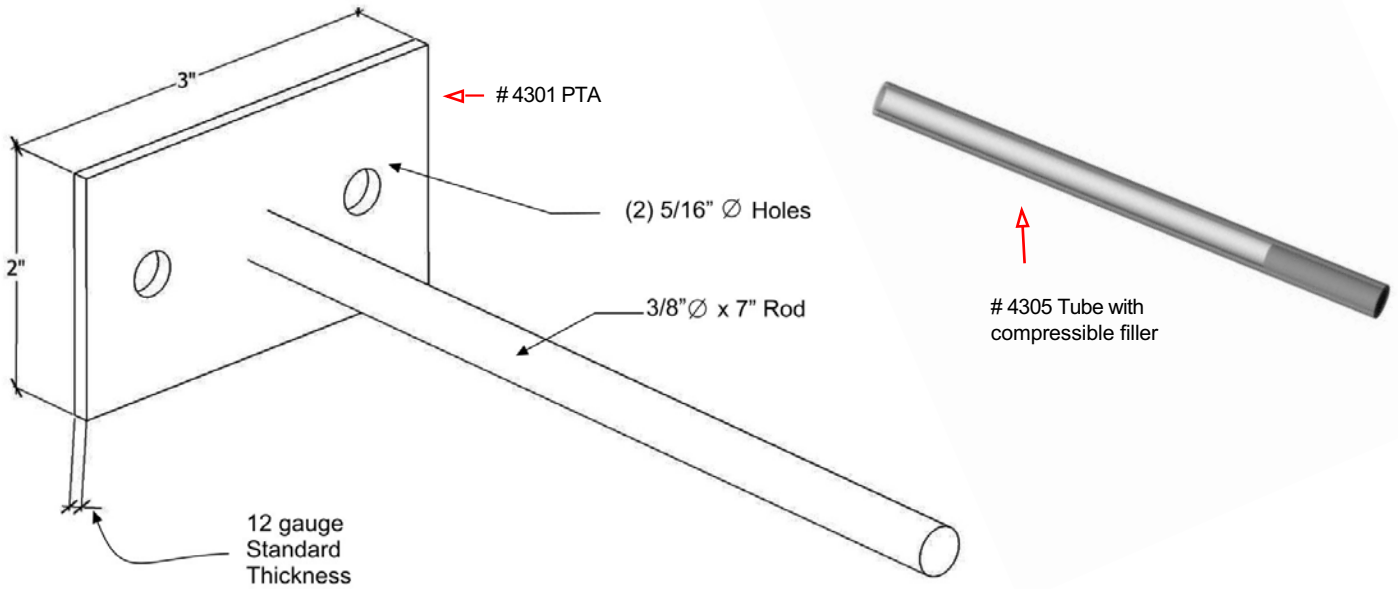

MATERIAL CONFORMANCE

SHEET METAL - (Carbon Steel) **ASTM A1008 / A1008M**

TUBE: Clear Butyrate **ASTM D542 , D148 , D696 , D257**

Mill Galvanized / Zinc Coating:**ASTM A641 / A641M (0.10 Oz per sq ft)**

Hot Dip Galvanized after fabrication / Zinc Coating
ASTM A153 / A153M-B2 (1.50 oz per sq ft)

Stainless Steel **ASTM 580 / ASTM 580M Type 304**
(Type 316 available on special order)

SIZES / FINISHES

4301 Plate:

12 gauge x 2" x 3"

1/4" x 2 x 3"

4301 Rod:

3/8" x 7"

FINISH:

Mill Galvanized Hot Dip Galvanized Stainless Steel

Recycled Content:

Mill Galvanized & Pot Dipped,
82.8% Post-Consumer
17% Post Industrial / Pre Consumer

Stainless Steel

97% Pre-Consumer V O C Content - 0%



www.wirebond.com

MASONPRO, Inc.
43300 Seven Mile Road
Northville, MI 48167
1-800-659-4731
www.masonpro.com